

SERIES 40-45
McCANNALOK

The Ultimate Valve For Snow Making



Bray Controls is proud to offer the McCannalok line of high performance butterfly valves. This product line is recognized as a proven leader with over 30 years of successful service in process industries worldwide. The Series 40's unique, patented design received Chemical Processing's Vaaler Award for Best Product shortly after it was introduced. The simple, innovative design offers rugged reliability and extremely easy maintenance in the field. Independent and internal tests have proven McCannalok's superior service life capability, with bubble tight shut off through over 100,000 cycles. The McCannalok high performance valve delivers the highest quality and highest value available for your snow making requirements.

- > High Performance
- > Zero Leakage
- > High Pressure Butterfly Valves

Wafer style offers bubble tight bidirectional shut off and for dead end service, lug bodies offer bidirectional bubble tight shut off, and both at full rated pressure

Wafer/Lug Bodies:

- Series 40/41 - ANSI Class 150
- Series 42/43 - ANSI Class 300
- Series 44/45 - ANSI Class 600

Temperature Range:

-20°F To 500°F (-29°C To 260°C)

- 1 - BODY:** One piece wafer body style or lug style for dead-end service. Both body styles offer bidirectional sealing as standard to full ANSI Class 150, 300 or 600 ratings. Standard body materials are either carbon steel or stainless steel for excellent corrosion resistance. Extended neck allows for 2" of pipeline insulation and easy access to stem packing adjustments and actuator mounting.
- 2 - STEM:** The high-strength, one piece stem is 17-4 PH stainless steel. The valve stem is standardized for interchangeability of Bray actuators.
- 3 - DISC:** The disc has been engineered to maximize flow and minimize resistance, providing a high Cv. 316 stainless steel is standard.
- 4 - TAPER PINS:** Taper pins are precision fit into taper reamed holes providing a positive connection of maximum strength between the valve disc and stem.
- 5 - INTERNAL TRAVEL STOP:** An internal travel stop has been designed to prevent over travel of the disc, minimizing possible seat damage, therefore extending the service life of the seat.



6 – GLAND ADJUSTMENT NUTS: A slight ¼ turn is usually all that is required should field adjustment ever be needed. Both hex head nuts must be evenly adjusted and not overtightened.

7 – STUD/BLOW-OUT PROOF STEM: The Series 40 valve features blow-out proof stem protection. A retaining ring is installed between the machined stem groove and gland retainer step providing full retention of the stem in the unlikely event of internal stem failure.

8 – GLAND RETAINER RING

9 – STEM SEAL: The stem seal system provides constant compression for a positive seal around the stem. PTFE packing seals the stem, and a carbon fiber anti-extrusion ring contains the packing. Flexible graphite rings are available for high temperature applications and are standard on fire safe valves.

All Class 150 and Class 300 valves have one set of stem seal packing rings and a stem locating plug with a gasket or O-ring seal in the body base. All Class 600 valves have upper and base twin stem seals which balance axial forces on the stem and disc under all operating conditions, and eliminate any piston effect on the stem.

10 – STEM BEARINGS: Top and bottom bearings, consisting of a 316 stainless steel shell with a TFE/glass fabric liner bearing surface, securely support the stem. The stem bearings provide excellent resistance to corrosion and distortion from high temperatures and mechanical loading forces.

11 – TWO PART SEAT ASSEMBLY: The unique, two-part seat assembly consists of a resilient energizer which is totally encapsulated by the UHMWPE seat.

12 – SEAT RETAINER: The assembly is locked in the body recess by a full-faced seat retainer.

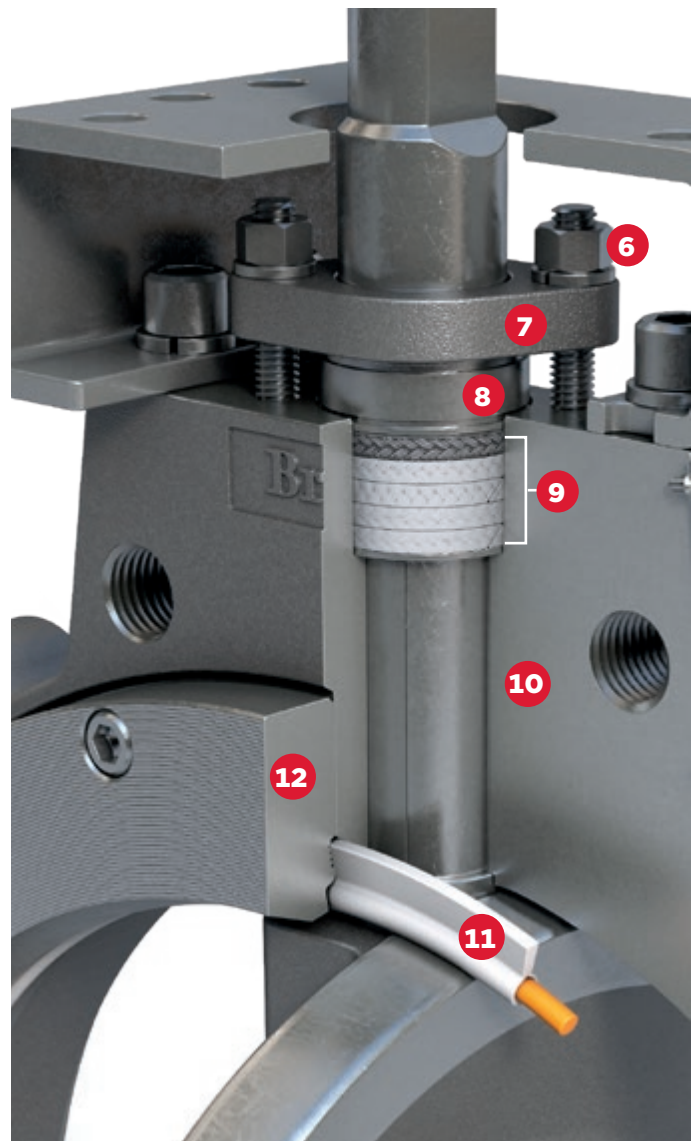

This simple, reliable and proven seat combination results in many exclusive advantages, including:

- > The energizer is completely isolated from all contact with the line media by the UHMWPE seat.
- > Serrations in the seat retainer and body recess secure the seat assembly in place regardless of disc position.
- > The full-faced retainer is bolted to the body, locking the seat in the correct position. The seat is secured even without the mating flange.
- > The closely confined and well supported seat is energized by the disc and line pressure. The higher the pressure, the tighter the seal. In low pressure and vacuum applications, the energized seat offers superior sealing and longer service life than many other designs.
- > Line media is sealed to zero leakage in both directions.
- > The seat is self-adjusting for wear and temperature changes.
- > Seat replacement is extremely easy – just remove the seat retainer, rotate the disc into the closed position and place a new seat assembly in the machined recess of the body. This simple procedure will not disturb the disc or stem.
- > The science of snow making can be quite complex. Snow making in its simplest form is the act of turning water into small ice crystals (snow). Four things come into play to make this happen: ambient temperatures, evaporation, surface area, super cooling. Commercial snow makers at ski areas typically use water from ponds. This water temperature is usually 34 to 40 degrees Fahrenheit. Pond water can have small particles of debris and/or the ambient temperature could be cold enough to form small ice particles, both of which in some cases could damage the seats of the valves. Bray has standardized on UHMWPE seats that have better performance against leaks with these small particles.

DOUBLE OFFSET STEM AND DISC DESIGN

The double offset design of the McCannalok ensures reduced seat wear, lower operating torque, and bidirectional, zero leakage shut off throughout the full pressure range.

At the initial point of disc opening, the offset disc produces a camming action, pulling the disc away from the seat. This camming action reduces seat wear and eliminates seat deformation when the disc is in the open position. When open, the disc does not contact the seat, therefore seat service life is extended and modulating torques are reduced. As the valve closes, the offset rotary motion of the disc effectively pushes the disc into the seat. During the last degrees of closure, the sweeping action of the disc against the seat prevents material build-up from slurries or suspended solids.

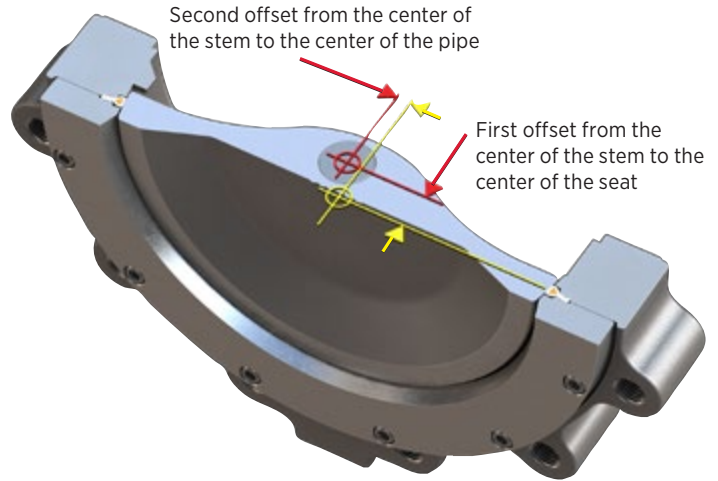

For over 30 years the reliability of the McCannalok has been conclusively proven, both in lab tests and thousands of field applications.

After a test of over 100,000 cycles at 720 psi, the seat remained in excellent condition, continuing to provide a bidirectional bubble tight seal. Even after more than 878,000 cycles at 2 psi, the Series 40 still sealed bubble tight in both directions.

MCCANNALOK ADVANTAGES OVER OTHER VALVES

Compared with ball, gate, globe and plug valves, the McCannalok provides cost savings for installation and maintenance. The lighter weight and ease of actuation make this design a superior choice. For larger sized and higher pressure rated valves, a drastic reduction of weight allows for a simplification of the entire piping system and reduction of costs associated with piping supports.

Economy in the costs of transportation and handling, efficiency in installation and maintenance, and proven performance

establishes the McCannalok as the best solution for demanding applications.

With operating torques lower than the competition, smaller actuation is required. This allows for smaller valve and actuator packages in limited installation footprints. The McCannalok is used for isolation and control in hydrocarbon and chemical processing, purified gas, steam, vacuum, potable water and more.

8 Inch (200mm) Class 150

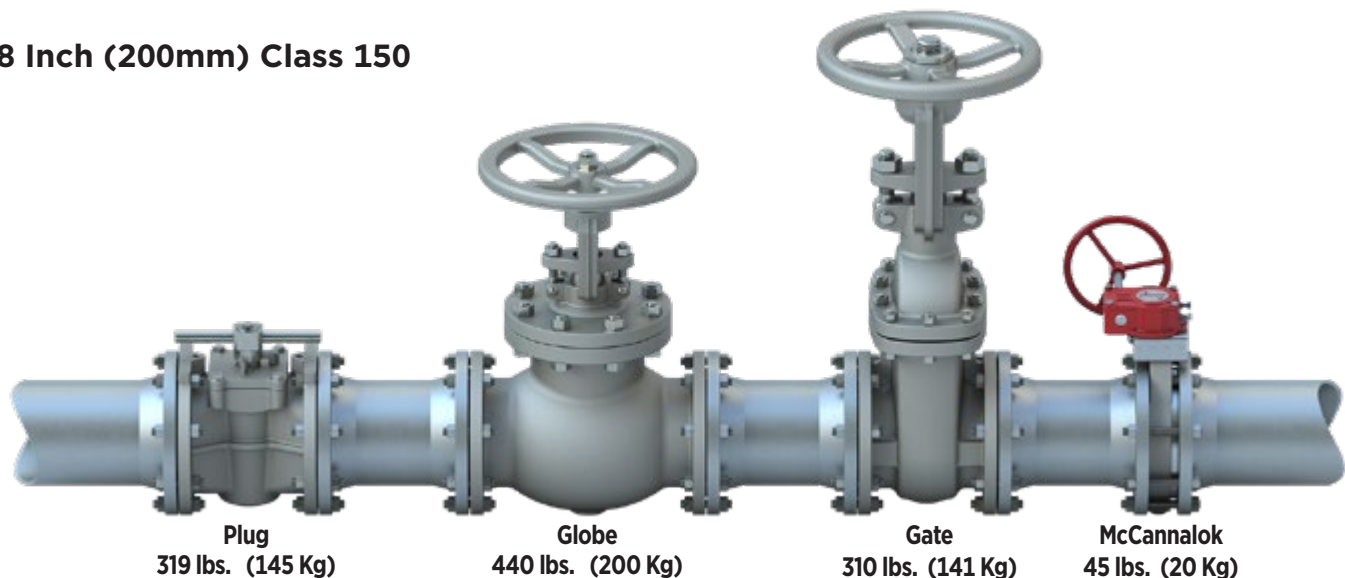

HIGH PRESSURE, HIGH AND LOW TEMPERATURE RANGES, ZERO LEAKAGE HIGH PERFORMANCE BUTTERFLY VALVES

Bray Controls is proud to offer the McCannalok line of high performance butterfly valves. This product line is recognized as a proven leader with over 30 years of successful service in process industries worldwide.

The McCannalok's unique, simple, innovative design offers rugged reliability and extremely easy maintenance in the field. Independent and internal tests have proven McCannalok's superior service life capability, with zero leakage shut off through over 100,000 cycles.

The McCannalok valves can be automated inexpensively with Bray's pneumatic and electric actuators.

The McCannalok High Performance Valve delivers the highest quality and highest value available for your requirements.



ASME Class 150

2" - 66" (50-1500MM)

ASME Class 300

2½"-54" (65-1400 MM)

ASME Class 600

3" -36" (80-900MM)

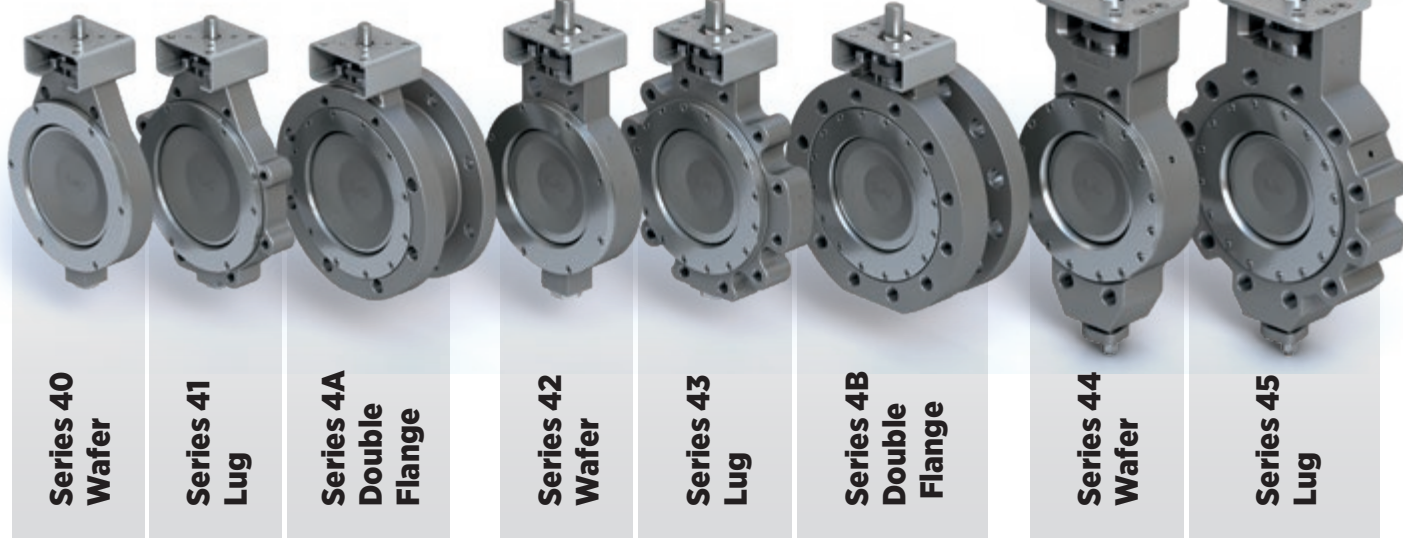

**Series 40
Wafer**

**Series 41
Lug**

**Series 4A
Double
Flange**

**Series 42
Wafer**

**Series 43
Lug**

**Series 4B
Double
Flange**

**Series 44
Wafer**

**Series 45
Lug**

TEMPERATURE RANGE: -320°F TO 900°F (-196°C TO 482°C)

Zero leakage, bidirectional shut off to full rated pressure.
Bray standard shut off testing meets API 598 requirements.

Dimensions are in inches and weights in lbs.

Weights are for cast steel bodies, except when noted by*.

* Flame cut body weights.

Flame cut steel and SS bodies vary. Please consult factory.

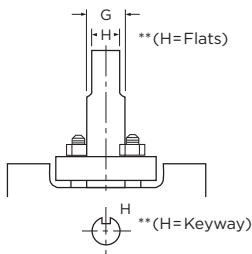
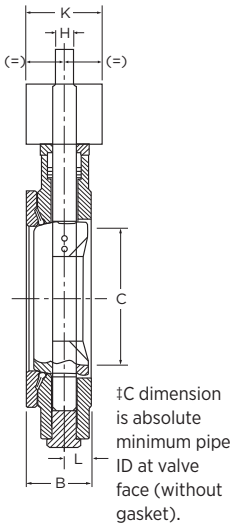
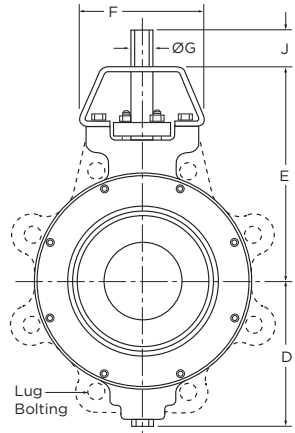
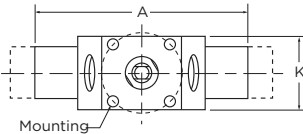

** Keyway is applicable on valve sizes 14"- 54" Class 150 valve sizes 10"- 48" Class 300 valve sizes 8"- 30" Class 600

ANSI 150 - Series 40															Series 41					
Valve Size		A	B	C†	D	E	F	Mounting Data			G	H**	J	K	L	Lug Bolting Data			Weights	
ins	mm							BCD	NO HOLES	HOLE DIA.						BCD	NO HOLES	THREADS UN-2B	S40	S41
2½	65	4.75	1.88	2.28	3.81	6.38	4.36	2.76	4	0.38	0.63	0.43	1.25	2.50	0.77	5.50	4	¾-11	13	14
3	80	5.25	1.88	2.86	4.09	6.63	4.36	2.76	4	0.38	0.63	0.43	1.25	2.50	0.77	6.00	4	¾-11	16	15
4	100	6.75	2.03	3.72	4.71	7.50	4.36	2.76	4	0.38	0.63	0.43	1.25	2.50	0.75	7.50	8	¾-11	20	23
5	125	7.50	2.23	4.80	5.07	7.50	5.12	2.76	4	0.38	0.75	0.51	1.25	4.50	0.94	8.50	8	¾-10	26	34
6	150	8.62	2.23	5.88	5.57	8.00	5.12	2.76	4	0.38	0.75	0.51	1.25	4.50	0.94	9.50	8	¾-10	33	47
8	200	10.75	2.40	7.80	6.94	9.50	5.12	4.92	4	0.53	0.87	0.63	1.25	4.50	0.94	11.75	8	¾-10	46	54
10	250	13.06	2.75	9.78	8.56	10.75	6.12	4.92	4	0.53	1.18	0.87	2.00	4.50	1.07	14.25	12	¾-9	79	94
12	300	15.50	3.08	11.74	10.18	12.25	6.12	4.92	4	0.53	1.18	0.87	2.00	4.50	1.13	17.00	12	¾-9	123	136
14	350	17.50	3.73	12.90	11.95	14.50	7.75	4.92	4	0.53	1.38	.39x.39	2.00	6.50	1.42	18.75	12	1-8	208	227
16	400	19.81	4.11	14.68	12.94	17.75	10.38	6.50	4	0.81	1.97	.47x.39	2.50	6.50	1.66	21.25	16	1-8	313	345
18	450	21.41	4.61	16.60	14.15	20.00	10.38	6.50	4	0.81	1.97	.47x.39	2.50	6.50	1.86	22.75	16	1½-8	402	442
20	500	23.68	5.03	18.50	15.26	22.75	10.38	6.50	4	0.81	2.50	.62x.62	4.00	6.50	2.06	25.00	20	1½-8	527	604
24	600	28.00	6.00	22.50	18.21	25.00	15.38	10.00	8	0.67	3.00	.75x.75	4.00	11.75	2.44	29.50	20	1½-8	813	930
26	650	29.50	6.50	22.36	19.23	25.00	15.38	10.00	8	0.67	3.00	.75x.75	4.00	11.75	2.81	31.75	24	1½-8	970*	1280*
28	700	32.41	6.50	26.47	20.54	26.75	15.38	10.00	8	0.67	3.00	.75x.75	4.00	11.75	2.81	34.00	28	1½-8	1115	1300
30	750	34.50	7.50	28.31	21.36	28.75	19.50	11.73	8	0.81	3.50	.88x.62	5.25	13.50	3.10	36.00	28	1½-8	1475	1740
32	800	37.62	7.50	30.19	22.36	30.00	19.50	11.73	8	0.81	3.50	.88x.62	5.25	13.50	3.22	38.50	28	1½-8	1650*	2060*
34	850	39.62	7.75	30.13	23.86	30.00	19.50	11.73	8	0.81	3.50	.88x.62	5.25	13.50	3.35	40.50	32	1½-8	1890*	2340*
36	900	40.68	8.26	34.00	25.27	33.00	19.50	11.73	8	0.81	3.50	.88x.62	5.25	13.50	3.63	42.75	32	1½-8	1960	2600
40	1000	51.00	9.50	36.99	27.25	37.00	19.50	11.73	8	0.81	4.50	1.0x.75	5.25	13.50	4.38	47.25	36	1½-8	3850*	3950*
42	1050	53.31	9.50	39.05	29.37	38.00	19.50	11.73	8	0.81	4.50	1.0x.75	5.25	13.50	4.38	49.50	36	1½-8	4250*	4300
48	1200	54.00	10.00	46.09	33.12	42.13	24.00	14.02	8	1.25	5.00	1.25x.88	6.00	16.00	4.50	56.00	44	1½-8	4610*	5680*
54	1400	66.38	10.75	52.45	35.65	45.50	24.00	14.02	8	1.25	6.00	1.5x1.0	6.50	16.00	4.75	62.75	44	1½-8	7100*	7210*
60	1500	73.00	12.50	57.07	39.44	50.75	26.00	15.98	8	1.50	7.00	1.75x1.50	7.50	18.70	4.75	69.25	52	1½-8	—*	9360*

ANSI 300 - Series 42															Series 43			S42	S43	
2½	65	4.75	1.88	2.28	3.81	6.38	4.36	2.76	4	0.38	0.63	0.43	1.25	2.50	0.77	5.88	8	¾-10	13	15
3	80	5.25	1.88	2.86	4.09	6.63	4.36	2.76	4	0.38	0.63	0.43	1.25	2.50	0.77	6.62	8	¾-10	16	17
4	100	6.75	2.03	3.72	4.71	7.50	4.36	2.76	4	0.38	0.63	0.43	1.25	2.50	0.75	7.88	8	¾-10	20	23
5	125	8.25	2.23	4.80	5.13	8.00	5.12	2.76	4	.038	0.75	0.51	1.25	4.50	0.94	9.25	8	¾-10	33	39
6	150	8.88	2.42	5.75	6.25	8.75	5.12	4.92	4	0.53	0.87	0.63	1.25	4.50	0.97	10.62	12	¾	40	54
8	200	10.94	2.82	7.56	7.55	10.00	6.12	4.92	4	0.53	1.18	0.87	2.00	4.50	1.10	13.00	12	¾-9	68	89
10	250	13.26	3.28	9.44	9.36	11.38	6.12	4.92	4	0.53	1.38	.39x.39	2.00	4.50	1.28	15.25	16	1-8	113	144
12	300	15.57	3.62	11.31	10.89	13.50	7.75	4.92	4	0.53	1.38	.39x.39	2.00	6.50	1.40	17.75	16	1½-8	173	217
14	350	17.90	4.66	11.38	12.50	18.25	10.38	6.50	4	0.81	1.97	.47x.39	2.50	6.50	2.13	20.25	20	1½-8	328	444
16	400	19.94	5.35	14.31	13.88	21.00	10.38	6.50	4	0.81	2.50	.62x.62	4.00	6.50	2.50	22.50	20	1½-8	455	592
18	450	22.00	5.98	15.00	15.43	21.00	15.38	10.00	8	0.67	2.50	.62x.62	4.00	11.75	2.65	24.75	24	1½-8	605	856
20	500	24.10	6.34	16.50	16.80	22.25	15.38	10.00	8	0.67	3.00	.75x.75	4.00	11.75	2.90	27.00	24	1½-8	780	1050
24	600	28.88	7.15	20.68	19.80	26.25	19.50	11.73	8	0.81	3.50	.88x.62	5.25	13.50	3.40	32.00	24	1½-8	1260	1720
30	750	35.12	8.98	26.81	23.40	32.25	24.00	14.02	8	1.25	4.50	1.0x.75	5.25	16.00	4.38	39.25	28	1½-8	2260	3010
36	900	42.00	10.67	33.13	27.12	36.25	24.00	14.02	8	1.25	5.00	1.25x.88	6.00	16.00	5.23	46.00	32	2-8	3320	4400
42	1050	50.75	11.50	38.88	29.25	40.50	26.00	15.98	8	1.50	6.00	1.5x1.0	6.50	18.70	5.13	47.50	32	1½-8	5000*	4700
48	1200	57.75	12.50	45.75	33.16	44.75	29.00	19.02	12	1.50	7.00	1.75x1.5	7.50	22.00	5.50	54.00	32	1½-8	—*	7000

ANSI 600 - Series 44															Series 45			S44	S45	
3	80	5.78	2.22	2.75	5.71	7.00	5.12	2.76	4	0.38	0.75	0.51	1.25	4.50	0.90	6.62	8	¾-10	24*	31*
4	100	7.00	2.77	3.56	7.04	8.50	5.12	4.92	4	0.53	0.87	0.63	1.25	4.50	1.15	8.50	8	¾-9	41*	58†
6	150	9.75	3.34	5.38	8.57	9.75	6.12	4.92	4	0.53	1.18	0.87	2.00	4.50	1.50	11.50	12	1-8	79*	119*
8	200	11.80	4.23	6.88	10.80	12.25	7.75	6.50	4	0.81	1.38	.39x.39	2.00	6.50	1.90	13.75	12	1½-8	155*	227*
10	250	14.09	4.82	8.50	14.62	17.00	10.38	6.50	4	0.81	1.97	.47x.39	2.50	6.50	2.15	17.00	16	1½-8	280*	400*
12	300	16.47	5.51	10.12	15.72	18.25	10.38	6.50	4	0.81	1.97	.47x.39	2.50	6.50	2.53	19.25	20	1½-8	386*	547*
14	350	18.03	6.09	10.88	17.48	19.75	15.38	10.00	8	0.67	2.50	.62x.62	4.00	11.75	2.90	20.75	20	1½-8	549*	750*
16	400	20.38	7.00	12.62	19.41	21.75	15.38	10.00	8	0.67	3.00	.75x.75	4.00	11.75	3.44	23.75	20	1½-8	752*	1100*
18	450	23.15	7.75	14.60	21.05	23.75	19.50	11.73	8	0.81	3.50	.88x.62	5.25	13.50	3.60	25.75	20	1½-8	1090*	1470*
20	500	25.15	8.50	16.37	23.21	25.75	19.50	11.73	8	0.81	4.00	1.0x.75	5.25	13.50	3.88	28.50	24	1½-8	1360*	1850*
24	600	29.38	9.13	19.87	27.71	31.00	24.00	14.02	8	1.25	5.00	1.25x.88	6.00	16.00	3.94	33.00	24	1½-8	2160*	2900*
30	750	36.00	11.25	26.50	31.50	36.00	26.00	15.98	8	1.50	6.00	1.5x1.0	6.50	18.70	5.00	40.25	28	2-8	3500*	4700*

PARTS DIAGRAM - STANDARD

No.	Description
1	Body
2	Disc
3	Stem
4	Soft Seat
5	Seat Retainer
6	Locating Plug
7	Gasket
8	Bearing
9	Disc Spacer
10	Drive Screw
11	Identification Tag
12	Thrust Washer
13	Stem Seal Set
14	Grounding Washer (optional)
15	Stud
16	Gland Ring
17	Retaining Ring
18	Lock Washer
19	Hex Nut
20	Mounting Bracket
21	Cap Screw
22	Taper Pin
23	Gland Retainer
24	Lock Washer
25	Cap Screw

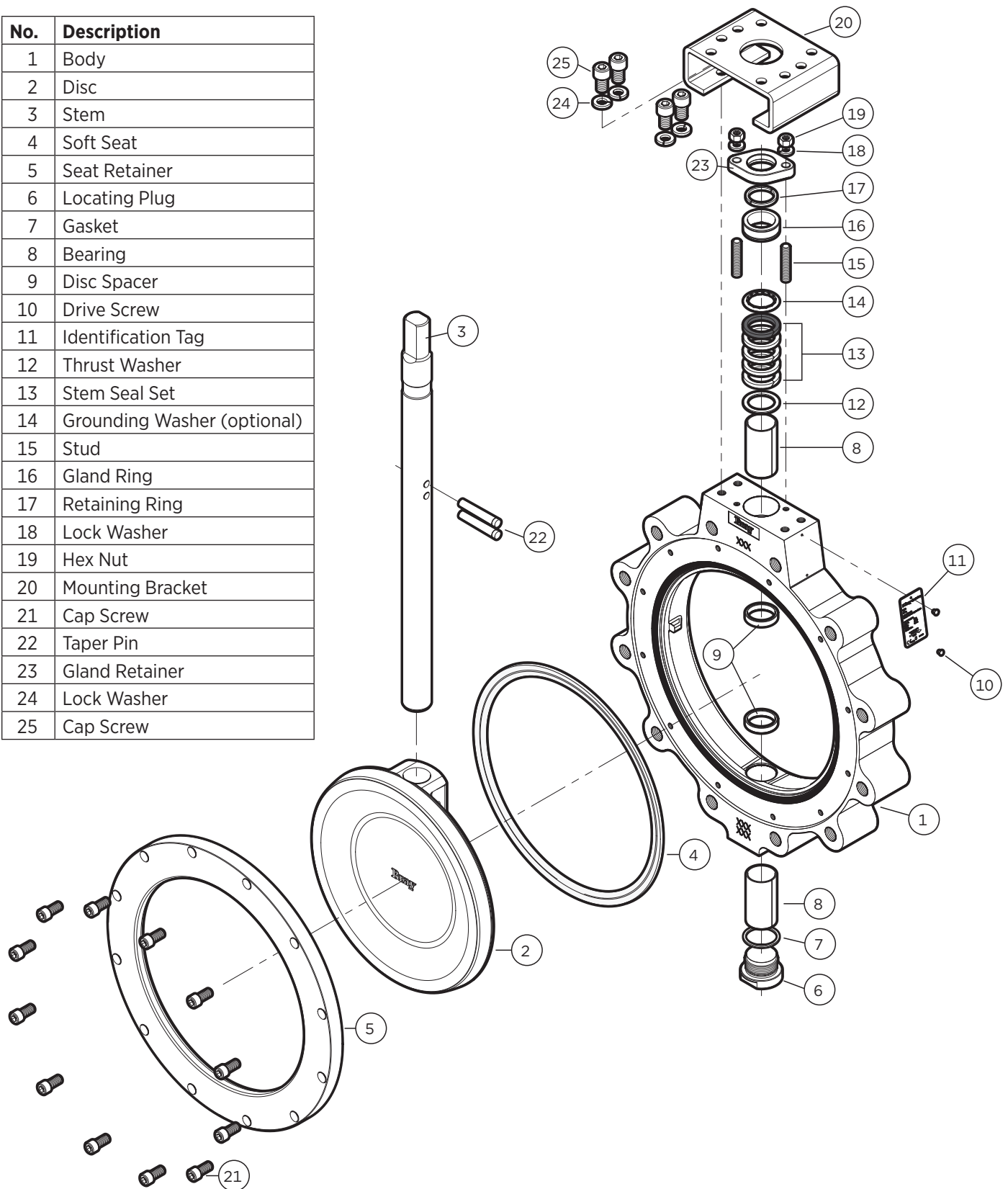

SINCE 1986, BRAY HAS PROVIDED FLOW CONTROL SOLUTIONS FOR A VARIETY OF INDUSTRIES AROUND THE WORLD.

VISIT **BRAY.COM** TO LEARN MORE ABOUT BRAY PRODUCTS AND LOCATIONS NEAR YOU.

HEADQUARTERS

Bray International, Inc.

13333 Westland East Blvd.

Houston, Texas 77041

Tel: +1.281.894.5454

All statements, technical information, and recommendations in this bulletin are for general use only. Consult Bray representatives or factory for the specific requirements and material selection for your intended application. The right to change or modify product design or product without prior notice is reserved. Patents issued and applied for worldwide. Bray® is a registered trademark of Bray International, Inc.

© 2024 BRAY INTERNATIONAL, INC. ALL RIGHTS RESERVED. BRAY.COM

EN_B-1067_Series 40_Snowmaking_3-25-2024



THE HIGH PERFORMANCE COMPANY